

Electromagnetic Flowmeter Type MAGNETOFLOW™ M2000

Description

The amplifier type M2000 is best suited for bidirectional flow measurement of fluids with a conductivity $> 5 \mu\text{S/cm}$ ($> 20 \mu\text{S/cm}$ for demineralized water). M2000 shows a high accuracy, is easy to use and can be chosen for a large and flexible applications spectrum. The backlit, four-line display shows all actual flow measuring data, daily and complete in-formation, including alarm messages. The standard amplifier has 4 programmable digital outputs, one digital input, power output and USB interface. Integrated test tools make the putting into operation and the service easier.

Measuring principle

The operating principle of the electromagnetic flow meter is based on Faraday's law of magnetic induction: The voltage induced across any conductor, as it moves at right angles through a magnetic field, is proportional to the velocity of that conductor. The voltage induced within the fluid is measured by two diametrically opposed internally mounted electrodes. The induced signal voltage is proportional to the product of the magnetic flux density, the distance between the electrodes and the average flow velocity of the fluid.



Features

- Accuracy $\pm 0,25\%$,
- Flow range 0,03 – 12 m/s,
- DN6 – DN2000,
- Backlit four lines LCD display,
- Power supply 85 – 265 VAC / 9 – 36 VDC,
- Four programmable digital outputs,
- IP67 housing,
- USB interface.

Technical data

Power supply	85 – 265 VAC, 45 – 65 Hz, <20 VA or optional 9-36 VDC
Analog output	0/4 - 20 mA, ≤ 800 ohms, flow direction is displayed upon a separate status output
Pulse /Frequency output	2 open collector outputs 24 V active, 20 mA, or 30 V passive, 100 mA max. 10 kHz 2 Solid State Relay outputs 48 Vac, 500 mA or open collector outputs 30 V passive, 100 mA max. 1 kHz
Status output	min./max. alarm, preselection meter, flow direction, error message
Medium control	separate electrode
Programming	3 keys
Interface	MODBUS RTU RS232 / USB in option
Flow range	0,03 – 12 m/s
Accuracy	$\geq 0,5$ m/s better $\pm 0,25\%$ of actual flow $< 0,5$ m/s $\pm 1,25$ mm/s of actual flow
Repeatability	0,1%
Flow direction	bi-directional
Pulse length	Programmable up to 10 s
Outputs	Short circuit safe and galvanically isolated
Low flow cut off	0-10%
Display	LCD, 4 lines / 20 characters, backlit, actual flow, 2 totalizers, status display
Housing	Powder coated aluminium die cast
Protection class	IP67
Cable insertion	Power and signal cable (outputs) 3 x M20
Signal cable	From detector M20
Ambient temperature	-20°C up to +60°C

Dimensions

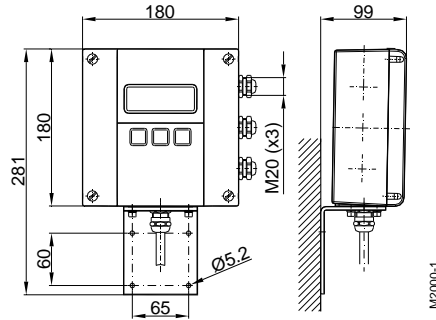

Detector type II Flange process connection

The electromagnetic detector type II is not only available in a number of different flange process connections (DIN, ANSI, JIS, AWWA, etc.) but also in a number of liners like hard rubber, soft rubber, PTFE, PFA or Halar. Available in sizes from DN 6 to DN 2000 and nominal pressures up to PN 100, the detector type II is best suited for a variety of applications in the industry and the water/waste water industry.

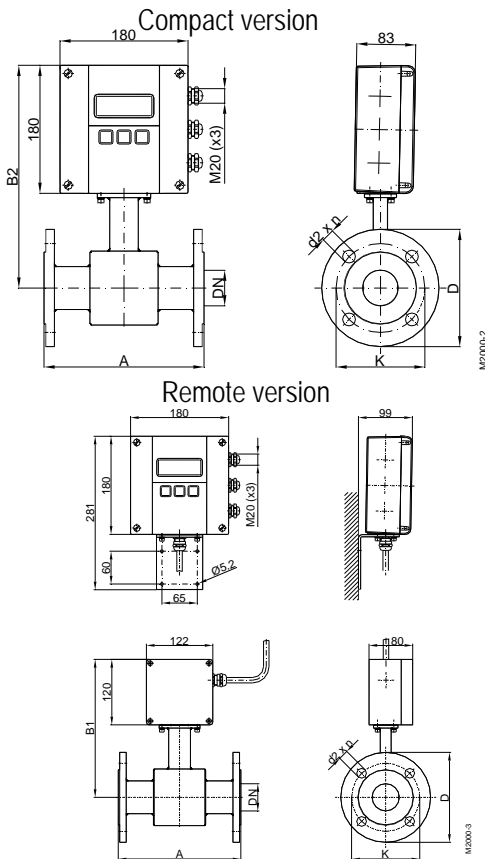

Technical data

Size	DN 6 – 2000 (1/4" ... 80")		
Process connections	Flange: DIN, ANSI, JIS, AWWA, etc		
Nominal pressure	up to PN 100		
Protection class	IP65, optional IP68		
Min. conductivity	5 µS/cm (20 µS/cm for demineralized water)		
Liner materials	Hard/soft rubber	from DN 25	0°C up to +80°C
	PTFE	DN 6 – 600	-40°C up to +150°C
	Halar (ECTFE)	from DN 300	-40°C up to +150°C
Electrodes materials	Hastelloy C (standard), Tantal Platinum / Gold plated, Platinum / Rhodium		
Housing	Steel / Optional stainless steel		
Approval	KTW, NSF61 and ACS (pending) for drinking water (Hard rubber only)		

Dimensions (mm)

DN	A*	B1	B2	with ANSI-flanges			with DIN-flanges			
				Ø D	Ø K	Ø d2xn	Ø D	Ø K	Ø d2xn	
6	1/4"	170	228	288	88,9	60,3	15,9 x 4	90	60	14 x 4
8	3/10"	170	228	288	88,9	60,3	15,9 x 4	90	60	14 x 4
10	3/8"	170	228	288	88,9	60,3	15,9 x 4	90	60	14 x 4
15	1/2"	200	238	298	88,9	60,3	15,9 x 4	95	65	14 x 4
20	3/4"	200	238	298	98,4	69,8	15,9 x 4	105	75	14 x 4
25	1"	200	238	298	107,9	79,4	15,9 x 4	115	85	14 x 4
32	1 1/4"	200	253	313	117,5	88,9	15,9 x 4	140	100	18 x 4
40	1 1/2"	200	253	313	127	98,4	15,9 x 4	150	110	18 x 4
50	2"	200	253	313	152,4	120,6	19 x 4	165	125	18 x 4
65	2 1/2"	200	271	331	177,8	139,7	19 x 4	185	145	18 x 4
80	3"	200	271	331	190,5	152,4	19 x 4	200	160	18 x 8
100	4"	250	278	338	228,6	190,5	19 x 8	220	180	18 x 8
125	5"	250	298	358	254	215,9	22,2 x 8	250	210	18 x 8
150	6"	300	310	370	279,4	241,3	22,2 x 8	285	240	22 x 8
200	8"	350	338	398	342,9	298,4	22,2 x 8	340	295	22 x 12
250	10"	450	362	422	406,4	361,9	25,4 x 12	395	350	22 x 12
300	12"	500	425	485	482,6	431,8	25,4 x 12	445	400	22 x 12
350	14"	550	450	510	533,4	476,2	28,6 x 12	505	460	22 x 16
400	16"	600	475	535	596,9	539,7	28,6 x 16	565	515	26 x 16
450	18"	600	500	560	635,0	577,8	31,7 x 16	615	565	26 x 20
500	20"	600	525	585	698,5	635,0	31,7 x 20	670	620	26 x 20
550	22"	600	550	610	749,3	692,1	34,9 x 20	---	---	---

DN	A*	B1	B2	with ANSI-flanges			with DIN-flanges			
				∅ D	∅ K	∅ d2xn	∅ D	∅ K	∅ d2xn	
600	24"	600	588	648	812,8	749,3	34,9 x 20	780	725	30 x 20
650	26"	600	613	673	869,9	806,4	34,9 x 24	---	---	---
700	28"	600	625	685	927,1	863,6	35,1 x 28	895	840	30 x 24
750	30"	800	650	710	984,2	914,4	34,9 x 28	---	---	---
800	32"	800	683	743	1060,5	977,9	41,3 x 28	1015	950	33 x 24
850	34"	800	708	768	1111,2	1028,7	41,3 x 32	---	---	---
900	36"	800	725	785	1168,4	1085,8	41,3 x 32	1115	1050	33 x 28
950	38"	800	750	810	1238,3	1149,4	41,3 x 32	---	---	---
1000	40"	800	790	850	1346,2	1257,3	41,3 x 36	1230	1160	36 x 28
1200	48"	1000	900	960	1511,5	1422,4	41,3 x 44	1455	1380	39 x 32
1350	54"	1000	975	1035	1682,8	1593,9	47,8 x 44	---	---	---
1400	56"	1000	1000	1060	---	---	---	1675	1590	42 x 36
Standard										
with ANSI-flanges		from DN 6 - 1400			Nominal pressure 150 lbs					
with DIN flanges		from DN 6 - 200			Nominal pressure PN 16					
		from DN 250 - 1400			Nominal pressure PN 10					
* ISO 13359 from DN 15 to 400										

Detector type III

Wafer connection

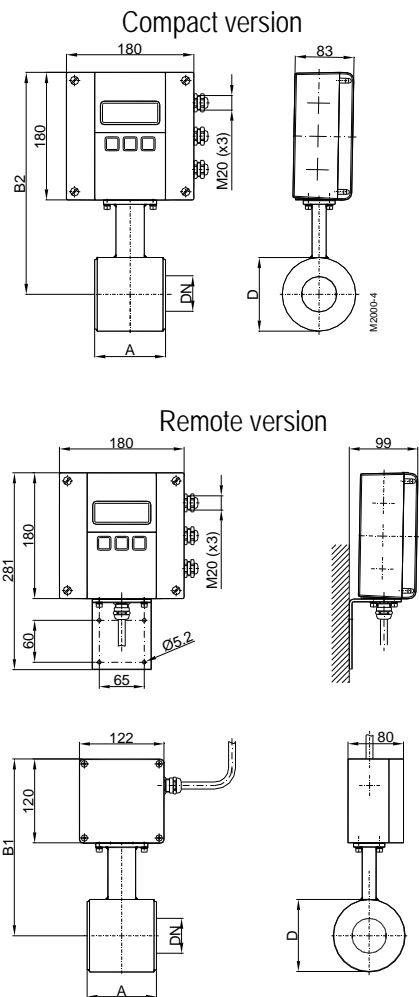

Thanks to its very short lay length, the detector type III is often the right alternative to a lot of applications. Delivered with a PTFE liner, the detector type III has a standard nominal pressure of PN 40.

Technical data

Size	DN 25 - 100 (1" ... 4")	
Process connections	Wafer connection (in-between flange mounting)	
Nominal pressure	PN 40	
Protection class	IP65, optional IP68	
Min. conductivity	5 μ S/cm (20 μ S/cm for demineralized water)	
Liner materials	PTFE	-40 up to +150°C
Electrodes materials	Hastelloy C (Standard) Tantal Platinum / Gold plated Platinum / Rhodium	
Housing	Carbon steel / optional stainless steel	
Lay length	DN 25 - 50	100 mm
	DN 65 - 100	150 mm

Dimensions (mm)

DN		A	B1	B2	D
25	1"	100	238	184	74
32	1 ¼"	100	243	189	84
40	1 ½"	100	248	194	94
50	2"	100	253	199	104
65	2 ½"	150	266	212	129
80	3"	150	271	217	140
100	4"	150	279	225	156
Nominal pressure PN 40					

Sanitary detector for Food

Process connections Tri-Clamp®, DIN 11851, ISO 2852, etc.

The sanitary detector was developed for the flow measurement of liquid food. This model is available with Tri-Clamp®, DIN 11851, ISO 2852 process connections and also with any special connections (customer specifications). The sanitary detector is delivered in a stainless steel housing and with PTFE/PFA lining.

Technical data

Size	DN 10 - 100 (3/8" ... 4")		
Process connections	Tri-Clamp®, DIN 11851, ISO 2852, etc.		
Nominal pressure	PN 10/16		
Protection class	IP65, optional IP68		
Min. conductivity	5 µS/cm (20 µS/cm for demineralized water)		
Liner materials	PTFE/PFA -40°C to +150°C		
Electrodes materials	Hastelloy C (Standard) Tantal Platinum / Gold plated Platinum / Rhodium		
Housing	Stainless steel		
Lay length	Tri-Clamp® connection	DN 10 – 50	145 mm
		DN 65 – 100	200 mm
	DIN 11851 connection	DN 10 – 20	170 mm
		DN 25 – 50	225 mm
DN 65 – 100	280 mm		

Dimensions (mm) type Food Tri-Clamp®

DN		A	B1	B2	D
10	3/8"	145	228	174	74
15	1/2"	145	228	174	74
20	3/4"	145	228	174	74
25	1"	145	228	174	74
40	1 1/2"	145	238	184	94
50	2"	145	243	189	104
65	2 1/2"	200	256	202	129
80	3"	200	261	207	140
100	4"	200	269	215	156
Nominal pressure PN 10					

Dimensions (mm) type Food DIN 11851

D	N	A	B1	B2	D
10	3/8"	170	238	184	74
15	1/2"	170	238	184	74
20	3/4"	170	238	184	74
25	1"	225	238	184	74
32	1 1/4"	225	243	189	84
40	1 1/2"	225	248	194	94
50	2"	225	253	199	104
65	2 1/2"	280	266	212	129
80	3"	280	271	217	140
100	4"	280	279	225	156
Nominal pressure PN 16					

Tri-Clamp® compact version

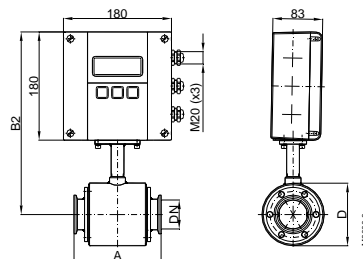

DIN11851 compact version

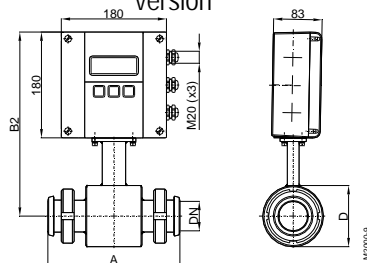

Tri-Clamp® remote version

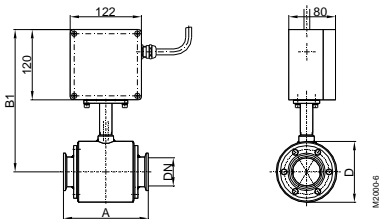
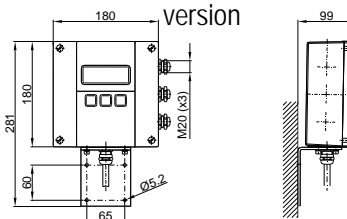

DIN11851 remote version

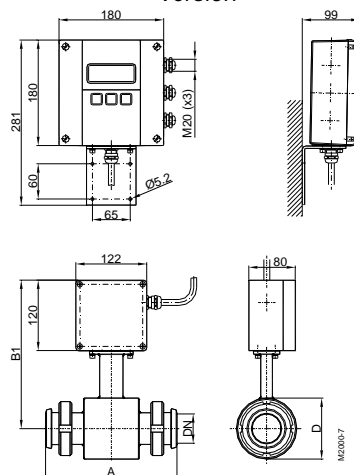

По вопросам продаж и поддержки обращайтесь:

Архангельск (8182)63-90-72
Астана +7(7172)727-132
Белгород (4722)40-23-64
Брянск (4832)59-03-52
Владивосток (423)249-28-31
Волгоград (844)278-03-48
Вологда (8172)26-41-59
Воронеж (473)204-51-73
Екатеринбург (343)384-55-89
Иваново (4932)77-34-06
Ижевск (3412)26-03-58
Казань (843)206-01-48

Калининград (4012)72-03-81
Калуга (4842)92-23-67
Кемерово (3842)65-04-62
Киров (8332)68-02-04
Краснодар (861)203-40-90
Красноярск (391)204-63-61
Курск (4712)77-13-04
Липецк (4742)52-20-81
Магнитогорск (3519)55-03-13
Москва (495)268-04-70
Мурманск (8152)59-64-93
Набережные Челны (8552)20-53-41

Нижний Новгород (831)429-08-12
Новокузнецк (3843)20-46-81
Новосибирск (383)227-86-73
Орел (4862)44-53-42
Оренбург (3532)37-68-04
Пенза (8412)22-31-16
Пермь (342)205-81-47
Ростов-на-Дону (863)308-18-15
Рязань (4912)46-61-64
Самара (846)206-03-16
Санкт-Петербург (812)309-46-40
Саратов (845)249-38-78

Смоленск (4812)29-41-54
Сочи (862)225-72-31
Ставрополь (8652)20-65-13
Тверь (4822)63-31-35
Томск (3822)98-41-53
Тула (4872)74-02-29
Тюмень (3452)66-21-18
Ульяновск (8422)24-23-59
Уфа (347)229-48-12
Челябинск (351)202-03-61
Череповец (8202)49-02-64
Ярославль (4852)69-52-93